

Technical Data

Technical data: Hydraulic power pack

Drive output	75 kW
Pump output	2 x 110 l/min (+1 x 35 l/min, optional)
Hydraulic fluid tank	350 l
Hydraulic fluid	HFC fluid, bio-oils, mineral oils
Oil filtration	line filter and return filter
Cooling	oil/water cooler or oil/air cooler
Dimensions (L x W x H)	3,765 x 800 x 840 mm
Weight	2,500 kg

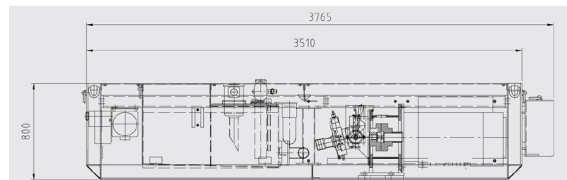

Hydraulic power pack

Technical data: Drilling machine type HLH 400

Drill thrust	120 kN
Drill return	170 kN
Tension-ram stroke	900 mm
Weight	2,100 kg
Rotary drive	HDR100 / HDR200 / HDR400 or equivalent
Drill hammer	B 650 R

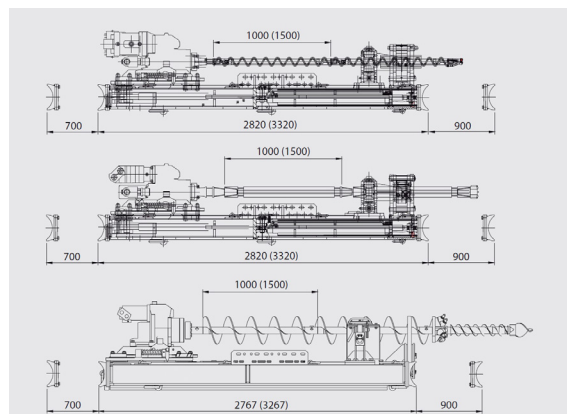

Drilling machine type HLH 400

Technical data: Drilling machine type HLH 110

Drill thrust	34 kN
Drill return	56 kN
Tension-ram stroke	1,000 mm
Weight	1,000 kg
Rotary drive	HDR100 / HDR200 or equivalent
Drill hammer	B 650 R

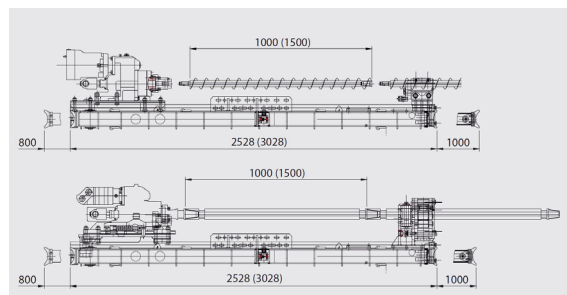

Drilling machine type HLH 110

HAZEMAG



HAZEMAG
Long-hole drilling equipment | HLH 400/110





Field of application and drilling techniques

HAZEMAG gas-borehole, long-hole and prospecting drilling equipment uses state-of-the-art drilling technology and guarantees high performance rates even in difficult operating environments, such as those encountered when drilling gas drainage holes and exploration holes for deep coal mining. The robust design, durability and efficiency of HAZEMAG drilling systems have been tried and tested under the toughest of conditions. This range of equipment can count among its main design features:

- high drilling performance
- multifunctional applications
- robust design for underground operations
- compact dimensions
- high availability
- sparing on drill tools.

Field of application, drilling techniques, drilling equipment

HAZEMAG gas-borehole, long-hole and exploration hydraulic drilling machines are mainly used for the drilling of boreholes for gas drainage and exploration purposes, but are also suitable for flush drilling, water drainage work as well as for drilling injection boreholes, core drilling and other tasks. HAZEMAG equipment is employed in all kinds of applications which require compact drilling machines for extension drilling operations.

The boreholes can be sited in all types of rock strata and coal seams and can also be drilled in fractured and unconsolidated ground. The drilled holes can also be cased, if necessary. Different borehole lengths and diameters can be drilled as a function of the characteristics of the drill rod and boring head (diameter and type).

Two basic types of machine – using either heavy or lightweight technology – are produced for the various drilling requirements. Both versions are available in rotary or percussive technology and in a range of models.

The drill tools and accessories can be supplied to match the drilling task and type of machine being used. Experienced technicians are on hand to help customers select the most suitable tools and drilling method.

Electrohydraulic drive system

Every HAZEMAG drilling machine is equipped with a compact hydraulic drive unit mounted in its own carrier frame and comes complete with all necessary drive elements, supply lines and monitoring instruments. A range of electric motors is available for every conceivable operating voltage and frequency. The hydraulic unit consists of several axial piston servopumps with pressure regulation. A choice of mineral oils, bio-oils or fire-resistant HFC fluids can be used as pressure medium. The hydraulic unit also contains a cooling and filtration system. Furthermore the operating operating temperature and filler level are monitored automatically.

Drilling control desk

The drill is controlled from a convenient and easy-to-operate control panel. For applications of the percussive drilling method the control includes a collaring stage, an automatic switch-on and switch-off of the hammer action and an automatic anti-jamming mode. For applications of the rotary drilling method the control includes an automatic drilling mode for automatic regulation of drilling advance dependent from drilling resistance (rotation pressure).



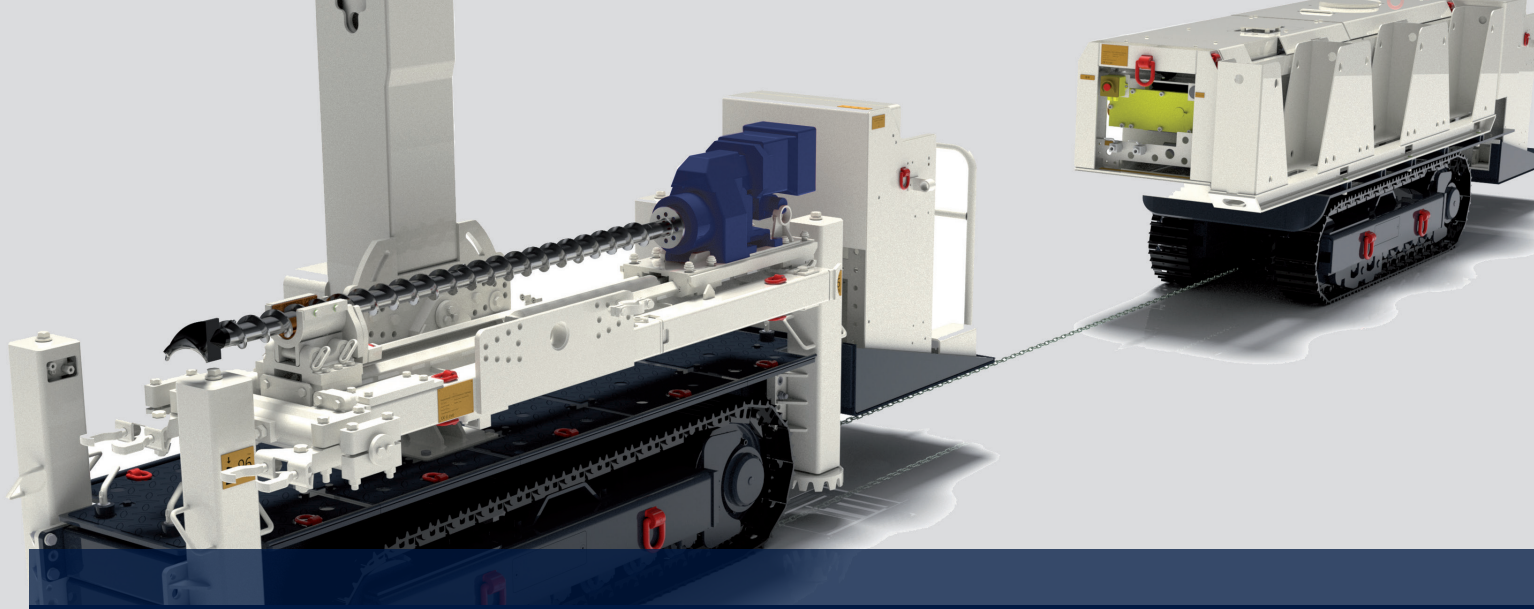

HLH 400 and HLH 110 two different versions and special equipment for your requirements

Drilling machine type HLH 400 – heavy version

The compact drilling machine with hydraulic rotary drive comprises a carrier frame in which a drill slide is moved back and forwards. The drill feed system is constructed as a direct drive unit with three interconnected hydraulic cylinders and is designed for high-powered thrust and retraction. Two hydraulically operated telescopic stanchions are fitted in front on both sides of the frame so that the machine can be braced in the drilling position. A further pair of mechanically or optional hydraulically adjustable props are incorporated into the lower section of the frame so that the machine can be adjusted to even floor conditions.

A drill-rod gripping and release device in the centre of the front frame is used for inserting and withdrawing the extension drill rods. A roller guidance system is used for centring the drill rod during drilling. The gripping and release device can act as a drill chuck, which engages hydraulically with the matching flats of the drill string, or as a hydraulic clamp, depending on the drilling task and drill-rod type. A positional display is used so that the chuck matching surfaces can be quickly run on to the gripping and release device.

Drill rod rotation is achieved through the use of a high-torque hydraulic rotary drive unit. Drives with different torque and rotation stages can be fitted to suit individual requirements. The rotary drive units also permit the use of downhole hammer drills for special applications. Rotary drives with rod feed-throughs and hydraulic jaw clamps are also available for core drilling work.

Drilling machine type HLH 110 – light version

The compact drilling machine with hydraulic rotary drive or percussion hammer drill consists of a torsio-

nally-rigid drill carriage with prism profiles. In addition to offering high wear resistance, the prismatic design creates a high-precision guidance system. The carriage is braced in the drilling position by means of two mechanically and two hydraulically extendable props.

The low-maintenance feed system is designed as a direct drive unit with a double-ram arrangement and requires no additional rope or chain deflection mechanism. When drilling with a percussion hammer drill a hydraulic drill-steel guide system is fitted to the front end of the carriage frame. This assembly helps to centre and guide the drill rod during the drilling operation and also acts as a clamping device for detaching the rod couplings and holding the drill rods in place in the borehole. The hydraulic rams attached to the clamping device are mounted on floating bearings in order to minimize wear and the entire unit can be mechanically swung out of the way mechanically for the subsequent insertion of the casing string.

When drilling with a rotary drive similar drill rod guide, gripping and release devices such as described in the heavy drilling machine version are used.

Accessories and special equipment

All HAZEMAG drilling machines can be fitted with a range of optional accessories, including air compressors, pressure booster pumps and hydraulically-powered drill support frames. Electronic control and radio remote control systems, which are also available as flameproof versions, can be supplied if required. The drilling machines can also be mounted on a wheel or crawler based undercarriage for mobile applications.

